

SAFETY & WARNINGS

READ AND FOLLOW ALL SAFETY INSTRUCTIONS

1. Do not cover strip light as the covering may cause the flexible light to overheat and melt or ignite.
2. Do not operate strip light while attached to plastic spool or tightly coiled. Excess heat may melt the spool and/or strip light.
3. Do not puncture, cut, shorten, or splice (hard-wire) strip light. Doing so causes risk of electric shock and will void the UL Safety Certification.
4. Do not use if there is any damage to the strip light or AC cord insulation. Inspect periodically.
5. All plastics are affected by the elements and may shift in color and other properties after product installation, particularly with direct exposure to sun, chlorinated water, and other chemicals.
6. Do not submerge strip light in liquids or use the product in the vicinity of standing water or other liquids.
7. Secure strip light using only hangers or mounting clips provided. Do not secure with staples, nails, its input wire, or like means that may damage the insulation or permanently attach the fixture to a building structure.
8. Do not subject strip light to continuous flexing.
9. Do not install near areas with exposure to salt water or chlorinated water.
10. Do not install in direct sunlight or damage to the LED phosphor will occur.
11. Do not attempt to fix this product in the field.

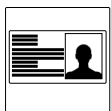

QUICK SPECS / MODELS

Input	120VAC, 60Hz	
Power	Foot	4.57W, 0.0381A / ft.
	Meter	15W, 0.125A / m
Max Run	200 ft. (60.97 Meters)	
Environment	Suitable for indoor and outdoor use. IP65	
Field-Cuttable	No	

Do not install product in environment outside listed temperature.

INFINILINE[®] X 120V LED Strip Light

INSTALLATION GUIDE

ADDITIONAL SAFETY & WARNINGS



WARNING!

THIS IS NOT A FIELD-CUTTABLE STRIP LIGHT.
DO NOT MODIFY THE STRIP LIGHT OR ATTACHED JUNCTION BOX.



HANDLE PRODUCT WITH CARE!



Do not bend LED strip light to a diameter less than 3 inches.

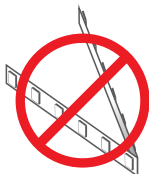

Do not fold or crease LED strip light.

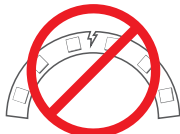

Do not bend LED strip light on a horizontal plane.



Do not put excessive pressure on surface of strip light (e.g. glass/acrylic panes etc.).

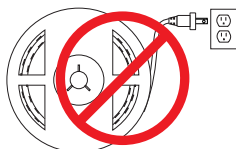

Do not power strip light while attached to spool or tightly coiled.



Do not cover strip light with any materials.

INSTALLING OUTDOORS?

When using outdoor use portable lighting products, basic safety precautions should always be followed. To reduce the risk of fire, electric shock, and personal injury, review the following:

READ ALL INSTRUCTIONS

PLUG-IN

- a** **GFCI PROTECTED OUTLET OR BREAKER**
Ground Fault Circuit Interrupter (GFCI) protection should be provided on the circuits or outlet to be used for the outdoor use flexible lighting product. Receptacles are available having built-in GFCI protection for this measure of safety. It is also recommended to install an outdoor outlet cover.



- b** **OUTDOOR EXTENSION CORD** (if needed):
Use only outdoor extension cords, such as type SW, SOW, STW, STOW, SJW, SJOW, SJTW, or SJTOW. This designation is marked on the wire of the extension cord. Ensure the extension cord is rated for the appropriate amperage of the attached load.



INFINILINE[®] X 120V LED Strip Light

INSTALLATION GUIDE

INSTALLATION

① TURN POWER OFF AT CIRCUIT BREAKER



SHOCK HAZARD! May result in serious injury or death.

Turn power OFF at circuit breaker prior to installation.

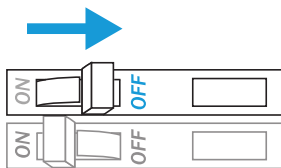

② UNCOIL STRIP LIGHT FROM SPOOL

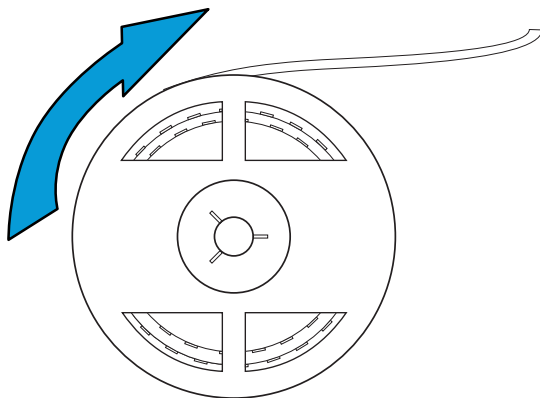

INSTALLATION (CONT.)

③ MOUNT STRIP LIGHT

Note: It is recommended to use at least 2 mounting clips per channel regardless of length.

3.1 SCREW MOUNTING CLIPS TO SURFACE

Measure and mark surface, then mount rotating mounting clips to desired position using Phillips head screwdriver.

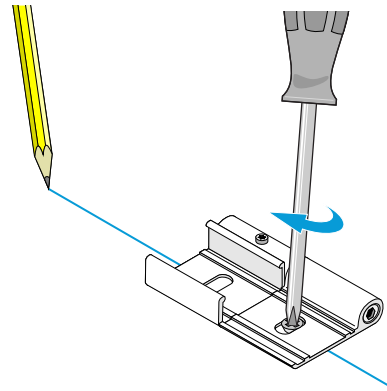

3.2 LOOSEN MOUNTING CLIP (OPTIONAL*)

Using Allen wrench and T-6 hex key, loosen screws within mounting clip.

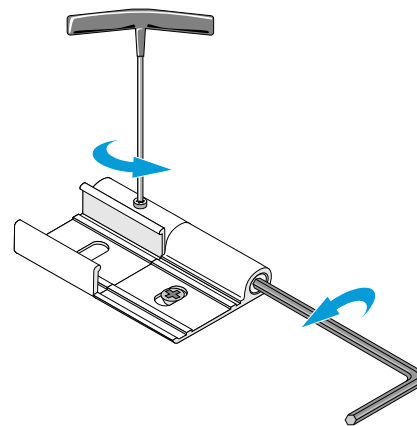

INFINILINE® X 120V LED Strip Light

INSTALLATION GUIDE

INSTALLATION (CONT.)

3.3 INSERT INFINILINE® X INTO CHANNEL

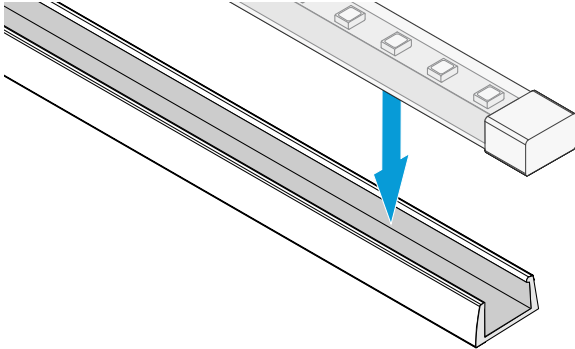

3.4 INSERT INFINILINE® X CHANNEL

Insert back edge of INFINILINE® X CHANNEL into mounting clip.

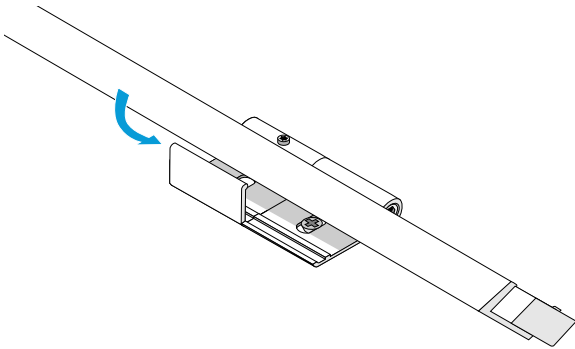

3.5 INSERT INFINILINE® X CHANNEL

Push down front edge of INFINILINE® X CHANNEL until secured into mounting clip.

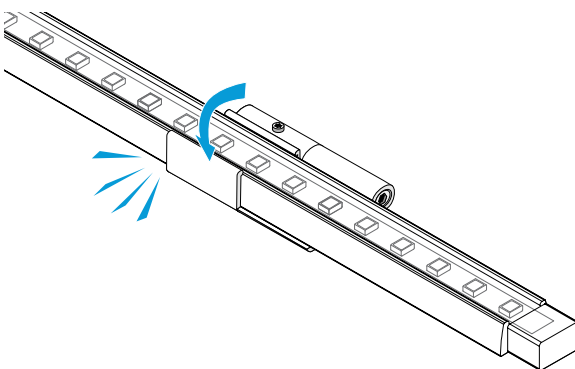

3.6 ADJUST MOUNTING CLIP (OPTIONAL)

Angle mounting clip into desired position.

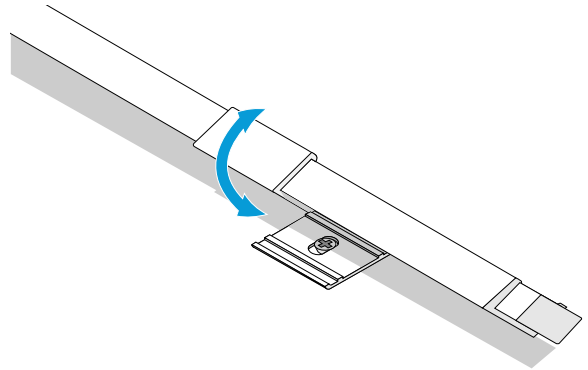

3.7 FASTEN MOUNTING CLIP

Tighten mounting clip screws using Allen wrench and T-6 hex key.

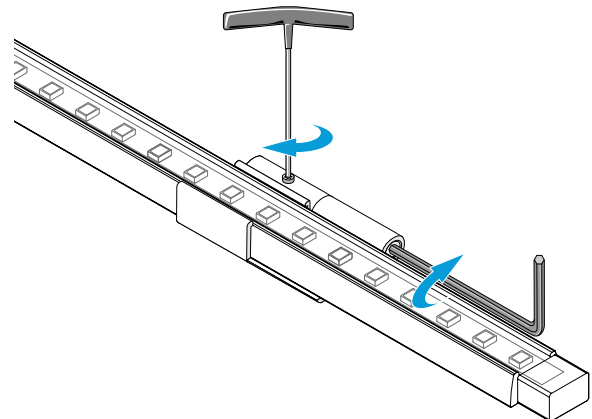

INFINILINE[®] X 120V LED Strip Light

INSTALLATION GUIDE

INSTALLATION (CONT.)

- 4 a** **CONNECT TO POWER (HARD WIRE)**
Insert connection wires into junction box.

4a.1

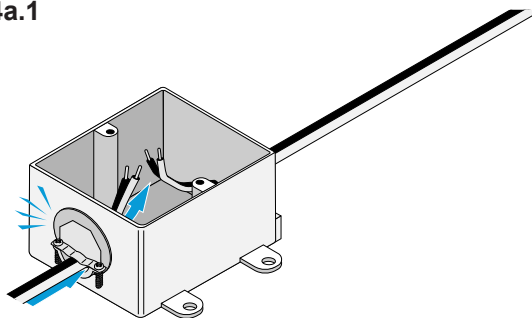

4a.2 Using twist-on wire connection, connect wiring within junction box.

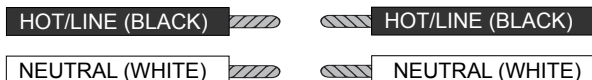
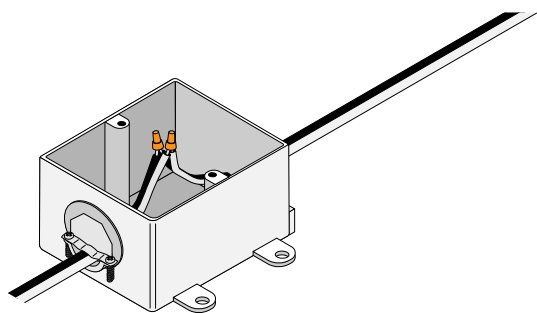

- 4 b** **CONNECT TO POWER (PLUG-IN)**
Connect to receptacle.

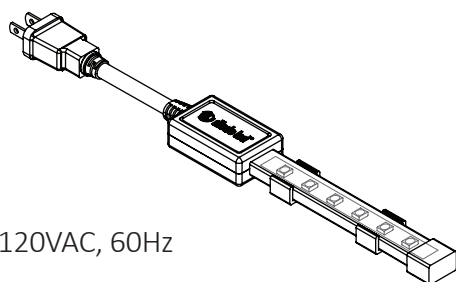
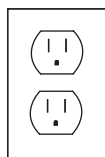

120VAC, 60Hz

- 5** **SEAL JUNCTION BOX (HARD WIRE)**
Using Phillips head screwdriver, fasten top to junction box.

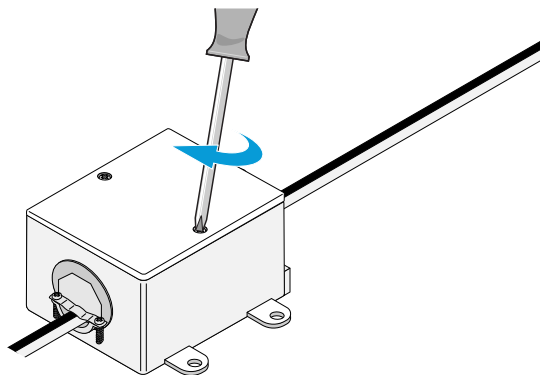

- 6** **TURN POWER ON AT CIRCUIT BREAKER**

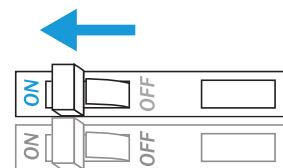

TROUBLESHOOTING

Some LED's are not functional	<ul style="list-style-type: none">• Ensure product has not been bent excessively, potentially breaking connections.
Lights are flickering	<ul style="list-style-type: none">• Verify strip is connected to a 120VAC, 60Hz circuit.
Lights will not illuminate	<ul style="list-style-type: none">• Ensure main power is turned On.• Check wiring to ensure proper polarity.

TOOLS & RESOURCES

INFINILINE[®] X SPECIFICATION SHEET

For full specifications.



Toll Free: 877.817.6028 | Fax: 415.592.1596 | www.DiodeLED.com | info@DiodeLED.com
© 2019 Elemental LED, Inc. All rights reserved. Specifications are subject to change without notice.